



**FM/FH/FR/FX SERIES**

FLAIL CHOPPERS

# WHEN FARMING MEANS BUSINESS

Realising the full potential of farming is about growing and developing your business, not only your crop or livestock, but also your profit. Improve productivity and profitability by focusing on the positives and minimising disadvantageous aspects, through strong, dedicated management.

Success springs from determination and clear targets, from laying down the appropriate strategy and allocating correct investments for the future. Quality results require the right ideas and equipment. When there is work to be done, you need the optimal setup and smart solutions that support you towards an easier, more profitable way of working. You need solutions that make tough and demanding conditions less complicated.





## PROCESS

Processing the crop efficiently will boost your grass management, ensuring the correct dry matter content and best possible nutritional value.

# FLAIL CHOPPER RANGE OVERVIEW

## WHAT ARE THE REQUIREMENTS FOR YOUR JOB?

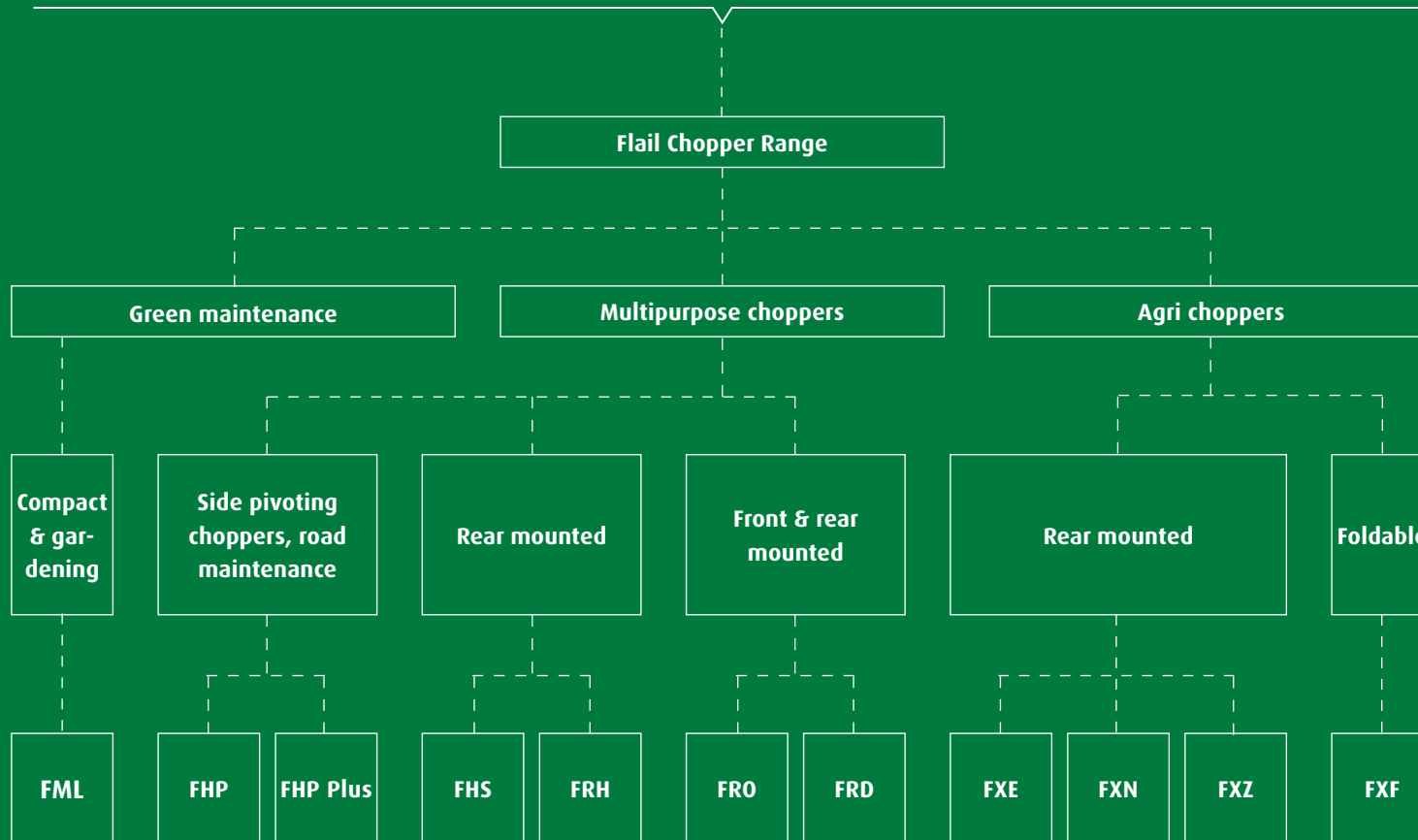

# GREEN AREA AND SPECIALITY CROPS FLAIL CHOPPERS



Green maintenance

Compact &  
gardening

FML



**Green Area and and Speciality  
Crops Choppers (FML)**

1.50-1.80m working width

Whether your requirement is for maintenance between rows in vineyards and orchards or the routine maintenance of grass in parks and other amenity areas, regular cutting is an essential task.

Efficient and environmentally friendly upkeep of these areas, either with a close cut for amenity purposes, or higher cutting for routine maintenance requires a machine with closely spaced flails and high rotor speeds.

This ensures the finest cut quality, whilst efficient mulching of crop residues facilitates rapid decomposition of residues for that perfect finish.

Kverneland FML choppers with their low power consumption and minimal maintenance requirement means that it has never been so easy to keep these areas attractive and tidy.



- ① **Perfect ground following** thanks upper and lower floating links
- ② **Stable transmission** with 3 V-belts and fixed tensioner
- ③ **Double skids** for easy maintenance low operating costs
- ④ **Maintenance free** bearing large diameter roller for nice work height control
- ⑤ **Light but robust body** fits best small tractors and heavy work
- ⑥ **Two different headstock positions** leave a possible mechanical offset at customer choice

## GREEN AREA AND SPECIALITY CROPS FLAIL CHOPPERS COMPACT SIZE



Category 1 headstock with floating lower and upper links.



All gearboxes on Kverneland choppers range feature as standard an integrated free wheel.

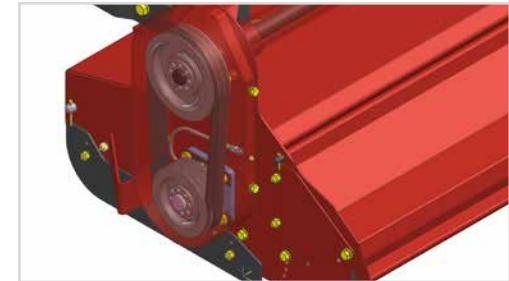

Belt transmission with simple tension system.



High rotor speed and universal blades offer best results for grassland maintenance and stubble chopping. Dynamic balanced rotor for precise quality and lowest noise on vibration level.

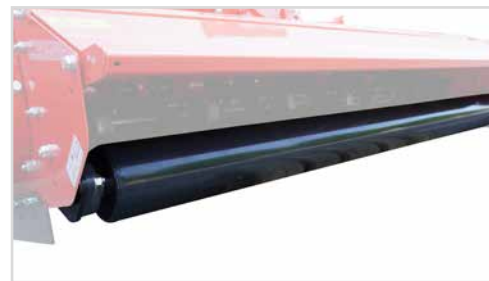

135mm diameter ground contour roller with integrated scrapper.





## THE SPECIALIST FOR GREEN AREAS

### Compact Size – Easy to Operate

The Kverneland FML grass chopper is a small, medium duty machine suited to operation use on slightly rough ground, green areas amenity areas, and tidying up pasture. It is available in three models with working widths from 1.50m to 1.80m, is very easy to operate and requires minimal maintenance.

As well as the universal blades fitted as standard, blades for stony conditions and cup blades can also be fitted on request. The FML is suitable for tractors up to 50hp and it is the perfect choice for green areas.

The core of the FML chopper is the rotor: fast rotation speed (2052rpm) in combination with a high number of blades give the FML a superb chopping performance. As standard the FML offers a mechanical offset: the headstock can be fitted in the centre or on the left side of the chopping unit.

*For tractors up to 50hp*

The FML is equipped as standard with a rear roller and skids which allows reliable cutting height control.





The cutting and shredding of crop residues has multiple agronomic benefits in a wide variety of situations, making the chopper a true multi-purpose tool. Whether in roadside maintenance, pasture land, headland management of field borders or between crops on arable or fallow land, efficient shredding of residues is an essential tool in good crop husbandry. The chopping and shredding of excess vegetation is an environmentally friendly way to control unwanted growth. Grass thrives by being cut and the resultant new growth is more appealing for animals to graze.

With the increasing use of minimal tillage systems for crop establishment, intensive shredding of crop residues or cover crops has become increasingly important. It promotes quick and efficient breakdown and aids reabsorption of organic matter back into the soil, thus improving soil structure and fertility. In these environmentally sensitive times it has also become more desirable than ever to avoid the use of chemicals wherever possible.

# MULTIPURPOSE FLAIL CHOPPERS





- ① **Robust headstock design** studied to perform in toughest conditions
- ② **Efficient rotor transmission** with 5 V-belts and BTS automatic belts tensing system
- ③ **High performance bearings** with grease nipples
- ④ **Large 160 to 245 mm diameter roller** ensures most efficiency ground following even in the softer soils
- ⑤ **Standard bolted skids** offer unique wearing plate that simplifies replacement and lowers maintenance costs
- ⑥ **Robust frame** built for the roughest conditions integrated with a counter knife as standard
- ⑦ **Easy operation and versatility** thanks to the side shift feature (hydraulic as option)

# MULTIPURPOSE FLAIL CHOPPERS

## EASY OPERATION



A strong offset headstock ensures best performances over long lifetime. Kverneland FRO & FRD offer also front linkage solution.



All gearboxes on Kverneland choppers range feature as standard an integrated free wheel.



BTS automatic belt tensioner ensures a stable rotor transmission in all working conditions.

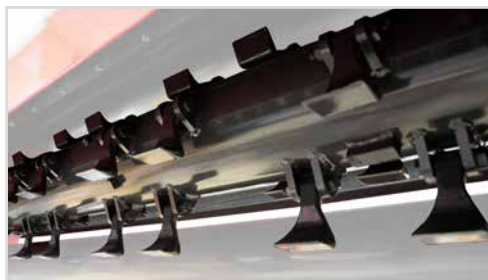

High linear tip speed and significant number of blades always ensure the best chopping results with all material type.



The 160mm big diameter roller with self cleaning system fitted as standard to maximise the field performances.



A number of optional accessories such a second counter knife or double skin are available for further customisation according to the needs.



1



2



3

1. Maximum versatility - Horizontal cutting.
2. Vertical cutting.
3. Tilting angle of -65 degrees.

## EFFICIENT WORKING IN ALL CONDITIONS

The Kverneland FHP (and its tall brother FHP Plus) are **multipurpose chopper** for road maintenance, clearing out field edges, ditches and hedges. In addition the FHP show versatility in operation on grass, light wood and bushes thus **being ideal for the maintenance of parks, gardens and road sides.**

### Offset articulation

Different offset positions can be reached by different working widths. Versatile in all conditions due to extremely efficient articulation (-65° & +90°).

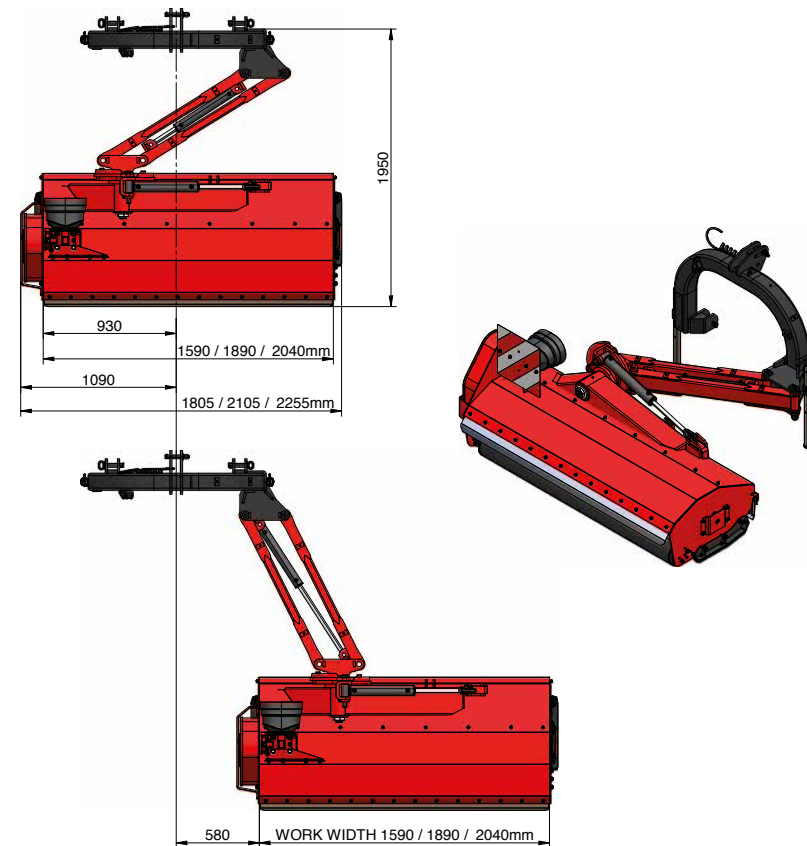

## MORE OFFSET - MORE VERSATILITY

### Compact and easy

Due to the possibility of different working angle positions, the FHP Plus is a highly versatile solution for farm and road maintenance purposes. Compact but robust it offers superb manoeuvrability and provide a high level of reliability.

Compared to the standard FHP chopper, the plus version offers greater offset (1255mm) and reaches positions and working angles impossible to get with other machines. In addition the FHP Plus can be combined with a front mounted chopper (FRO or FRD), to maximise working width.

### Lateral transmission

Powerful transmission by gearbox with integrated freewheel and five belts which incorporate an automatic tensioner, provide stable rotor speed even when working in tough conditions. A PTO shaft with wide angle joint is fitted as standard equipment.







### Robust and guarded

Main frame and parallelogram articulation designed for intensive use and extreme demanding conditions; heavily tested in Kverneland Group Klepp laboratory to ensure reliable and long working life. Gearbox and transmission are protected against misuse during operation.

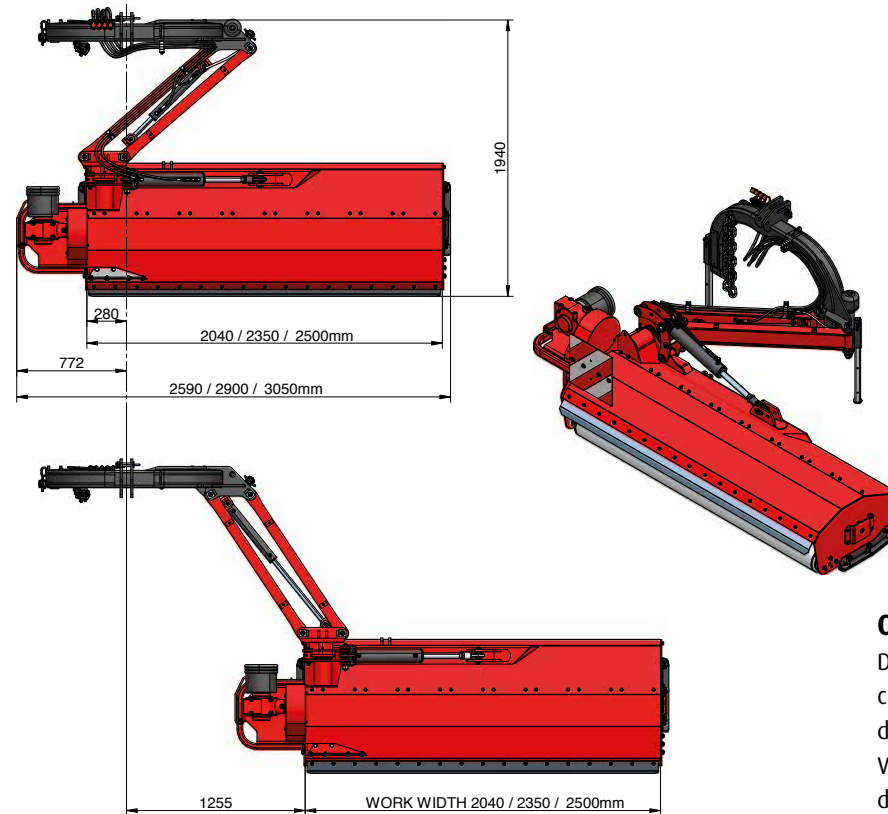

### Offset articulation

Different offset positions can be reached by different working widths. Versatile in all conditions due to extremely efficient articulation (-65° & +90°).

## EFFICIENT AND DURABLE!

### Compact heavy duty machine

The Kverneland FHS Chopper is a **compact and heavy duty machine for moderately demanding jobs in soft grounds top fruit orchards, vineyards and light undergrowth**. It is also equally fitting for tidying pasture and other grass fields, chopping straw and stubble.

Due to its rugged construction the FHS **ensures a long lifetime with minimal maintenance**. Adjustable headstock offset up to 500mm adds versatility for reaching under fruit trees and safer working close to the edges of drainage channels.

*Excellent shredding effect with minimal power requirement*

As an option, the hydraulic adjustment of the offset can be specified. In addition the standard roller and the skids support the chopper and **provide a consistent working height**.

### Modern and versatile

The design of the FHS is modern and versatile; the latest generation rotors can be **equipped with different types of blades, making them adaptable to most conditions**. The highest rotor speeds (2160rpm) in combination with a counterknife and a double skin, guarantee an excellent shredding **effect with minimal power requirement**.



The Kverneland FHS can be equipped with rake tines to improve chopping on prunings.



A 160mm diameter roller with an adjustable scraper is fitted as standard equipment and ensures correct field performance.





# VERSATILE AND RELIABLE



The Kverneland FRH is a multi-purpose machine for chopping grass, pasture, set-aside land and stubble. The hydraulic offset facility of the FRH gives you the possibility to clear out field edges, orchards and road edges. A choice of hammer blades or universal Y blades with short fan blades produce perfect shredding quality in all conditions.

## Performance

A massively strong tube with dimensions of 245 x 10mm forms the basis of the rotor. The large overall working diameter of the rotor (540mm) guarantees an excellent cut with a low power requirement. The counterknife and the double skin are suggested for a finer shredding of residues and a longer working life of the frame. Skids and a roller are standard equipment and provide accurate control of working height. The roller has a 245mm diameter and is self-cleaning (thanks to the blades running close to the roller profile).

## Low power requirement

With an offset facility of up to 52cm the FRH range is the ideal solution for field and farm maintenance. In addition the large diameter of the rotor (540mm) guarantees excellent cut quality with low power requirement. Easy and minimal maintenance make the FRH a cost effective machine to operate.

## Frame

The headstock is designed and tested for heavy applications. With all forces and stress concentrated on the three point linkage.

## Transmission

Central gearbox with an integrated free wheel as standard complies with the heavier operations. The drive pulleys are reversible allowing for operation with either 540 or 1000rpm input speed. Five grooved V-belts combined with an automatic tensioner ensure smooth power transmission. No maintenance required.

## FRONT, REAR, OFFSET!

### **Multi-purpose - for chopping grass, pasture, set-aside land and stubble**

A strong double headstock allows mounting the machine in front or behind the tractor. Together with an hydraulic offset facility, it gives multi purpose versatility for nearly all conditions e.g. clearing out field edges, orchards, road edges. Available with hammer blades or universal Y blades combined with fan blades.

*Smooth drive, reduced wear - longer lifetime*





### Hydraulic Offset

Ideal for clearing out field edges. Versatile use also for road maintenance. The precisely aligned offset frame of the machine after the welding process ensures **strong and reliable** guidance. Greaseable nylon bushes ensure a **long lifetime**.

### Lateral Drive

Kverneland FRO is driven by five VX type V-belts running on invertible pulleys which **allows adaptation for 540 or 1000rpm drive**. The idler wheel with automatic tensioner spring always ensures stable and low wear on belt drive while offering the safety that is needed to protect the machine from over-usage.

### Auto-alignment

The central gearbox fitted into the headstock **ensures that the pto-shaft remains at the same angle in all working positions**. Even on max. 500mm offset the pto angle does not change. **This guarantees a smooth drive, reduced wear and a longer lifetime** of the pto shaft and the whole driveline (crosses and yokes).





## VERSATILITY COMBINED WITH EFFICIENCY



Double headstock.



Front mounting.

Double headstock allows front or rear mounting of the FRD. Sliding tube integrated in the headstock; all forces are concentrated on the three point linkage.

### Robust Transmission

It has standard fit 52cm hydraulically operated offset facility and a central gearbox rated up for resisting the hardest conditions with double integrated free wheel as standard. The drive pulleys are reversible allowing for operation with either 540 or 1000rpm input speed. Five V-belts combined with an automatic belt tensioner ensures smooth power transmission, preventing slippage in the toughest working conditions. No maintenance is required. The double headstock allows front or rear mounting of the FRD. Sliding tubes are integrated in the headstock; all stress is concentrated on the three point linkage. It has standard fit 52cm hydraulically operated offset facility.



Efficient shredding of crop residues can be considered as a valuable addition to soil fertility and an essential tool in the promotion of good crop husbandry. With the increasing use of minimal tillage systems for crop establishment, the intensive shredding of crop residues or cover crops has become increasingly important. It is essential to promote a quick and efficient breakdown, aiding reabsorption of organic matter back into the soil, thus improving soil structure and fertility.

In large scale operations, especially where residues can be mature or bulky, the requirement is for a chopper with a wider working width and which is built to withstand the rigours imposed by use on higher horsepower tractors under intensive working conditions.

# AGRI FLAIL CHOPPERS

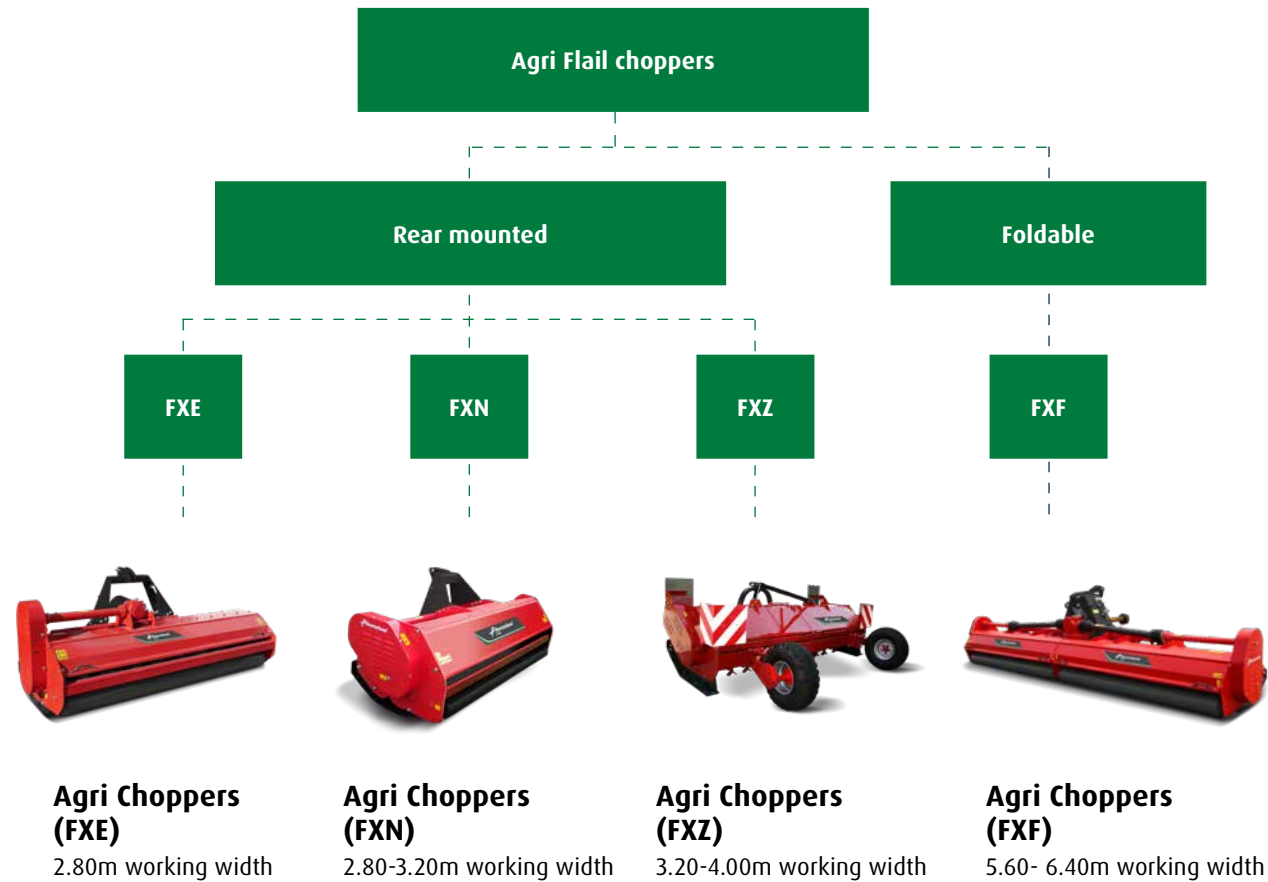

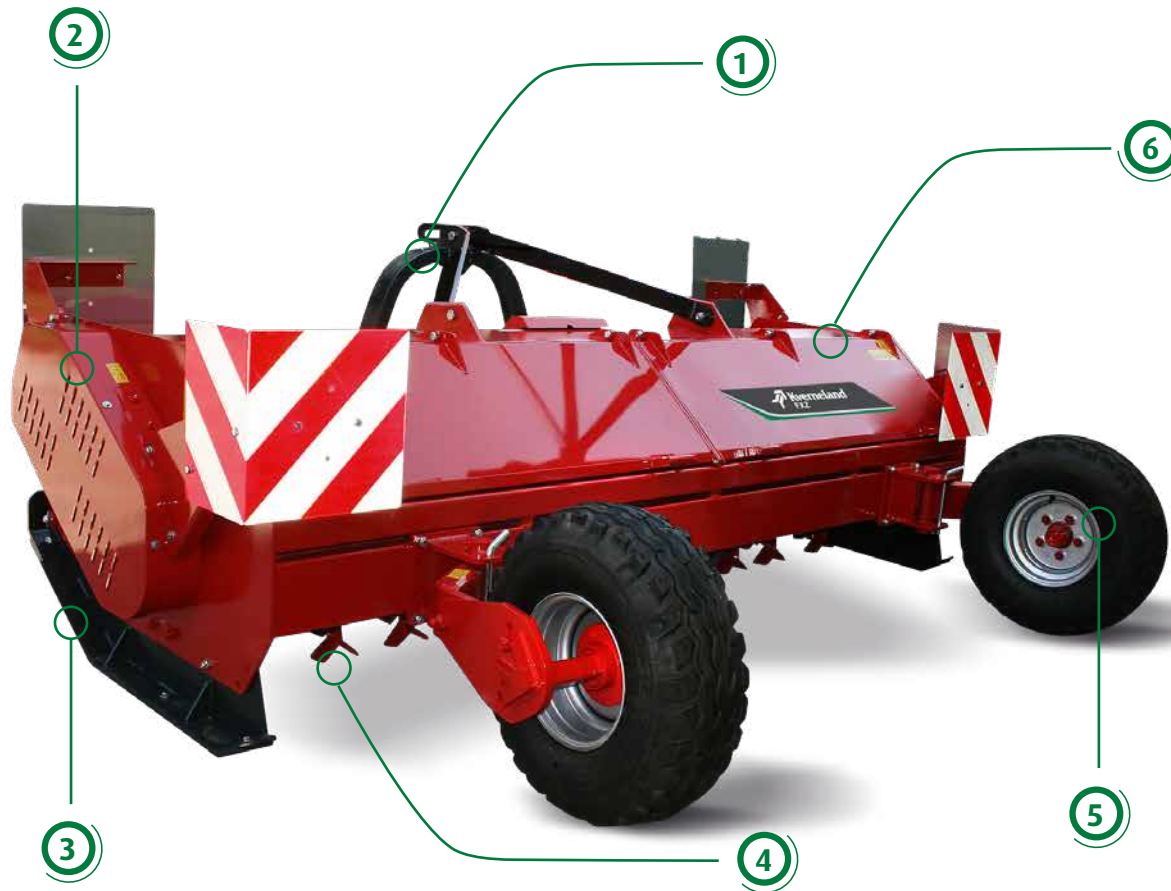

- ① **Headstock** designed and tested for heavy applications
- ② **Powerful V-belts transmission** ensuring perfect rotor drive even in the toughest situation
- ③ **External and centralized greasing points** for the rotor ensuring a fast maintenance
- ④ **Easily interchangeable bolted wearing plates** on the skids
- ⑤ **Pivoting wheels** allow nice ground following even in soft or sandy soils
- ⑥ **High chopping chamber** guarantees blockage free performance in even the heaviest crop flows

## AGRI FLAIL CHOPPERS SUITABLE FOR DIFFERENT CROPS



A strong headstock ensures a long lifetime even on the heavy duty chopper bodies.



All gearboxes on Kverneland choppers range feature an integrated free wheel as standard.



The transmission of the agri-chopper range is designed for maximum power transfer and minimal maintenance.



Special hammer design or fan or universal blades creates a suction effect lifting material and improving cutting.



Best ground following and field cleaning is achieved by using either back roller or wheels according to soil type.

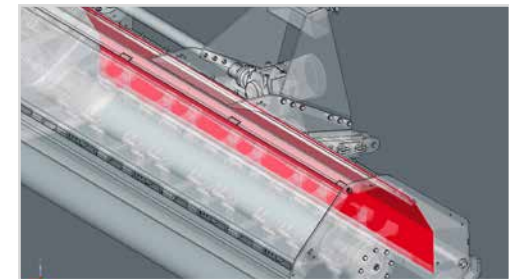

A number of optional accessories such as second counter knife or double skin are available for further customisation according to the needs.



## EXCELLENT PERFORMANCE

as well as very limited power requirement and maintenance activities (low operating costs) make the FXE chopper the ideal choice for farmers and contractors.

## EXCELLENT PERFORMANCE – LOW OPERATING COSTS

### **An agri chopper suitable for different crops**

The Kverneland FXE is an agri chopper suitable for grassland renewal, maize, sunflower and sorghum shredding. The frame of the chopping unit is designed with a curved profile, while the rear cover can be opened to handle large amounts of crop residue. In addition, the high chopping chamber guarantees blockage free performance even in the toughest conditions.

The roller bearings are integrated and protected and do not need regular greasing. The semi pivoting wheel kit is also maintenance free. A double skin and a second counter knife can be added as accessories in order to extend the life of the chassis and create finer chopped residues.

*Range of accessories  
- to fulfill all operating requirements*

# THE FLAIL CHOPPER FOR SPECIALISTS

## Great versatility in all conditions

The FXN range comprises Kverneland's largest and toughest grass and straw choppers built for heavy-duty work on set-aside land and cultivated fields. It is also suited to fruit farms, clearing scrub and tidying pasture. The FXN is available in 4 working widths covering all operating requirements.

## *Heavy construction for reliable operation*

## Unique versatility and high field performance

Kverneland FXN choppers offer unique operational versatility. The high rotor speed combined with a large number of blades increases the cutting efficiency, while reducing the input power required. The rotor is manufactured precisely and is dynamically balanced after the blades have been fitted; this provides smooth running without vibration.

## Range of accessories

The FXN can be equipped with different blade types in order to fulfill all operating requirements. Skids are included in the standard configuration. Wheels are optionally available. Furthermore a double skin and second counterknife are also optionally available. However, all models are solidly constructed with a robust gearbox and very strong power transmission to the "V" belts driving the rotor. In addition, a strengthened chassis incorporates double plating in the areas subjected to highest stress.

The combination of Kverneland's precisely manufactured rotor shafts and hard wearing blades makes the FXN models extremely reliable.







## THE KING OF THE CHOPPERS!

### More than 40 years experience

The Kverneland FXZ range has been designed to fulfill the most demanding requirements and to provide comprehensive chopping of crop residues for more effective decomposition. The development of these choppers was focused on the requirements of intensive users. They are ideal for very demanding and specialized contractors. The FXZ is excellent for shredding crop residues, chopping straw, maize and sunflower stalks as well as set-aside land.



Semi pivoting wheels (10/8.0 x 12.8 ply) as standard ensure good stability and a constant working depth of the FXZ during field operations. Semi automatic linkage (Cat III) allows fast coupling of FXZ. In addition the floating top link mounting permits easy control of the working height without stressing the headstock.



The FXZ is always equipped with a double lateral transmission. External and centralized greasing points for the rotor ensure a quicker maintenance.





### Rotor

The same rotor can be equipped with either Y blades or hammer blades; in all configurations special fan blades lift the material up for a better shredding effect. The large diameter (760mm) guarantees an excellent cut with low power requirement.



# HIGH PERFORMANCE POTENTIAL

## High performance rotor for excellent shredding in all conditions

The FXF foldable is particularly suitable for tractors up to 260hp, with working widths from 5.60 to 6.40m. Wide in the field - narrow on the road. Despite the wide working width the FXF folds to 2.50m transport width.

The highly efficient rotor, which works at a speed of 2025rpm ensures excellent chopping in all conditions, thanks to its diameter of 540mm, and 144 blades plus fan blades. Highest rotor speeds (2025rpm) in combination with a counterknife and a double skin, guarantees an excellent shredding effect with minimal power requirement.

The lateral transmission with five belts tensioned automatically. Available as an option are pivoting wheels or rollers that guarantee a constant working height.

The FXF offers maximum reliability, efficiency and versatility. This comes of 40 years of experience in building choppers.



The central gearbox is equipped with free wheels; the lateral transmission with automatic belt tensioners ensures reliability and a low maintenance requirement.



Working width from 560 to 640cm. The standard roller (Ø245mm) is running close to the profile to ensure a self-cleaning effect.



Semi pivoting wheels (10/8.0 x 12.8 ply) available as option ensure good stability and a constant working depth during field operation.



Transport width 250cm.

# ORIGINAL PARTS & SERVICE

## LET'S FOCUS ON YOUR BUSINESS

ORIGINAL  
PARTS

- 
- ① LONG LASTING, HIGH QUALITY SPARE PARTS
  - ② OVER 100 YEARS OF PARTS KNOWLEDGE
  - ③ SUPPORT FROM A WIDE NETWORK OF DEALERS
  - ④ 24/7 SPARE PARTS SERVICE
  - ⑤ HIGHLY SKILLED DEALER TECHNICIANS

# MYKVERNELAND

## SMARTER FARMING ON THE GO

### A personalised online platform tailored to your machine needs

With MYKVERNELAND you will benefit from easy access to Kverneland's online service tools.

Receive first hand access to information on future developments and updates, operator and spare part manuals, FAQs and local VIP offers. All information is gathered in one place.



# TECHNICAL DATA

	Green Area and Speciality Crops		Side Pivoting Flail Choppers					
Model	FML		FHP			FHP Plus		
<b>Dimensions &amp; Weight</b>								
Working width (cm)	150	180	155	185	200	200	230	250
Transport width (cm)	170	200	180	210	225	255	285	305
Weight (kg)	300	335	740	780	820	900	960	985
<b>Attachment to Tractor</b>								
Pto input speed (rpm)	540		540	1000	1000	1000		
Min-Max. power requirement (hp)	30 - 50		45 - 100			70 - 130		
<b>Operation</b>								
No. of universal blades	80	96	40	48	52	52	60	64
No. of hammer blades	-	-	20	24	26	26	30	32
Rotor speed (rpm)	2052		1800			1858		
Blade tip speed (m/s)	40		43			44		
Rotor shaft diameter (mm)	40		50			50		
Rotor diameter (mm)	102		169			169		
Cutting diameter (mm)	376		452			452		
No. of belts	3		5			5		
Belt tensioner	manual		automatic			automatic		
<b>Equipment</b>								
Offset (mm)	-		580			1250		
Rear roller (mm)	135 ●		195 ●			195 ●		
Rear wheels	-		-			-		
Skids	●	●	●	●	●	●	●	●
I counter knife	-	-	●	●	●	●	●	●
II counter knife	-	-	○	○	○	○	○	○
Double skin	-	-	●	●	●	-	-	-



	Flail Choppers for Green Area and Vineyards				
Model	FHS				
Dimensions & Weight					
Working width (cm)	155	185	200	230	250
Transport width (cm)	177	207	222	252	272
Weight (kg)	475	540	572	620	655
Attachment to Tractor					
Pto input speed (rpm)	540				
Min-Max. power requirement (hp)	60 - 80				
Operation					
No. of universal blades	40	48	52	60	64
No. of hammer blades	20	24	26	30	32
Rotor speed (rpm)	2160				
Blade tip speed (m/s)	51				
Rotor shaft diameter (mm)	50				
Rotor diameter (mm)	169				
Cutting diameter (mm)	452				
No. of belts	5				
Belt tensioner	automatic				
Equipment					
Offset (mm)	500				
Rear roller (mm)	160 ●				
Rear wheels	-				
Skids	●	●	●	●	●
I counter knife	●	●	●	●	●
II counter knife	○	○	○	○	○
Double skin	●	●	●	●	●

● Standard equipment ○ Option - Not available

# TECHNICAL DATA

	Multipurpose Flail choppers							
Model	FRO			FRH			FRD	
<b>Dimensions &amp; Weight</b>								
Working width (cm)	235	280	325	235	280	320	280	320
Transport width (cm)	255	300	345	255	300	345	300	345
Weight (kg)	863	980	1080	1025	1135	1225	1220	1380
<b>Attachment to Tractor</b>								
Pto input speed (rpm)	540 or 1000			540 or 1000			540 or 1000	
Min-Max. power requirement (hp)	95 - 140			100 - 160			100 - 160	
<b>Operation</b>								
No. of universal blades	40	48	56	56	72	80	72	80
No. of hammer blades	20	24	28	28	36	40	36	40
Rotor speed (rpm)	1730 - 1828			1844 - 1949			1844 - 1949	
Blade tip speed (m/s)	46 - 48			52 - 55			52 - 55	
Rotor shaft diameter (mm)	60			60			60	
Rotor diameter (mm)	220			245			245	
Cutting diameter (mm)	503			541			541	
No. of belts	5			5			5	
Belt tensioner	automatic			automatic			automatic	
<b>Equipment</b>								
Offset (mm)	500			550			550	
Rear roller (mm)	195 ●			245 ●			245 ●	
Rear wheels	○	○	○	-	-	-	-	-
Skids	●	●	●	●	●	●	●	●
I counter knife	●	●	●	●	●	●	●	●
II counter knife	○	○	○	○	○	○	○	○
Double skin	○	○	○	○	○	○	○	○

	Agri Flail choppers						
Model	FXE	FXN		FXZ		FXF	
<b>Dimensions &amp; Weight</b>							
Working width (cm)	280	280	320	320	400	560	640
Transport width (cm)	300	302	342	352	432	250	250
Weight (kg)	940	1174	1302	1750	2200	2400	2700
<b>Attachment to Tractor</b>							
Pto input speed (rpm)	540 or 1000	540 or 1000		1000		1000	
Min-Max. power requirement (hp)	75 - 130	100 - 160		100 - 260		130 - 260	
<b>Operation</b>							
No. of universal blades	68	72	80	120	152	144	160
No. of hammer blades	34	36	40	60	78	72	80
Rotor speed (rpm)	1789 - 1887	1844 - 1949		1603		2025	
Blade tip speed (m/s)	56 - 59	63 - 66		64		57	
Rotor shaft diameter (mm)	45	60		60		60	
Rotor diameter (mm)	194	245		273		245	
Cutting diameter (mm)	600	651		767		541	
No. of belts	5	5		2 x 4		2 x 5	
Belt tensioner	manual	automatic		manual		automatic	
<b>Equipment</b>							
Offset (mm)	540 ○	-		-		-	
Rear roller (mm)	245 ○	245 ○		-		245	
Rear wheels	○	○	○	●	●	○	○
Skids	●	●	●	●	●	○	○
I counter knife	●	●	●	●	●	●	●
II counter knife	○	○	○	○	○	○	○
Double skin	○	○	○	○	○	○	○

● Standard equipment ○ Option - Not available

Information provided in this brochure is made for general information purposes only and for worldwide circulation. Inaccuracies, errors or omissions may occur and the information may thus not constitute basis for any legal claim against Kverneland Group. Availability of models, specifications and optional equipment may differ from country to country. Please consult your local dealer. Kverneland Group reserves the right at any time to make changes to the design or specifications shown or described, to add or remove features, without any notice or obligations. Safety devices may have been removed from the machines for illustration purposes only, in order to better present functions of the machines. To avoid risk of injury, safety devices must never be removed. If removal of safety devices is necessary, e.g. for maintenance purposes, please contact proper assistance or supervision of a technical assistant. © Kverneland Group Ravenna S.r.l.

# TECHNICAL DATA

Usage	Mounting	Model	Horse Power Rate (hp)				Blades vs Crop			
			0	100	200	300	Grass Light	Various Medium	Wood Tuff	
 Green	Rear compact (gardening)	FML	[Progressive bar from 0 to ~25]							
 Multipurpose	Side Pivoting (road maintenance)	FHP	[Progressive bar from 0 to ~100]							
		FHP Plus	[Progressive bar from 0 to ~150]							
	Rear	FHS	[Progressive bar from 0 to ~25]							
		FRH	[Progressive bar from 0 to ~100]							
	Front & Rear	FRO	[Progressive bar from 0 to ~100]							
		FRD	[Progressive bar from 0 to ~150]							
	 Agri	Rear Mounted	FXE	[Progressive bar from 0 to ~100]						
			FXN	[Progressive bar from 0 to ~150]						
FXZ			[Progressive bar from 0 to ~250]							
Foldable		FXF	[Progressive bar from 0 to ~200]							







**WHEN FARMING MEANS BUSINESS**

[kverneland.com](https://kverneland.com)